

# BVT-IF

## TECHbrief

Wyatt-Badger Venturi Tubes  
Insert-Type Fabricated Primary Elements



### FEATURES:

- Low Pressure Loss
- High Accuracy
- Low Installed Cost
- Custom Designed
- Short Laying Length

### Description

The Wyatt-Badger BVT-IF is a fabricated insert venturi flow element that offers repeatability and accuracy over a greater range of flow rates and has lower permanent pressure loss than orifice plates, flow nozzles, or traditional venturi meters. These units can be manufactured from virtually any material to address the needs of your applications. The BVT-IF is designed for insertion within the interior of a pipeline and is secured by the adjacent pipe flanges. These venturi elements are characterized by longevity of service and flexibility in design.

### Application

The fabricated insert BVT-IF is designed to measure the flow of gases and liquids that have low solids loading. The BVT-IF can operate over extreme temperature and/or pressure ranges with highly corrosive fluids or gases. The BVT-IF has the distinct advantages of minimal weight, cost, and laying length. Typical applications range from potable water, cooling water, process water, steam, air flow for fine bubble aeration, combustion air, and natural and process gases.

### Flow Measurement Accuracy

For pipe Reynolds numbers greater than 75 000 and a normalized piping configuration, the Wyatt-Badger Venturi Tube provides a flow measurement accuracy of  $\pm 0.50\%$  without flow calibration. With independent flow calibration, Wyatt Engineering's insert BVTs provide the user with  $\pm 0.25\%$  accuracy.



**WYATT**  
engineering

*Intelligent Flow Measurement™*

5144 South 94th East Avenue, Tulsa, Oklahoma 74145-8172 Ph: 918 280 9775 Fx: 918 280 9113

Em: solutions@wyattflow.com

www.wyattflow.com

# Technical Specifications

## Accuracy

For pipe Reynolds numbers greater than 75 000 and a normalized piping configuration, the Wyatt-Badger Venturi Tube provides a flow measurement uncertainty of:

- ± 0.50% for standard meters and
- ± 0.25% for flow calibrated meters.

## Pressure Loss

The permanent pressure loss of the BVT-IF is significantly lower than that of short-form venturis, and for most beta ratios, lower than that of long-form venturis as well (See Figure 1).

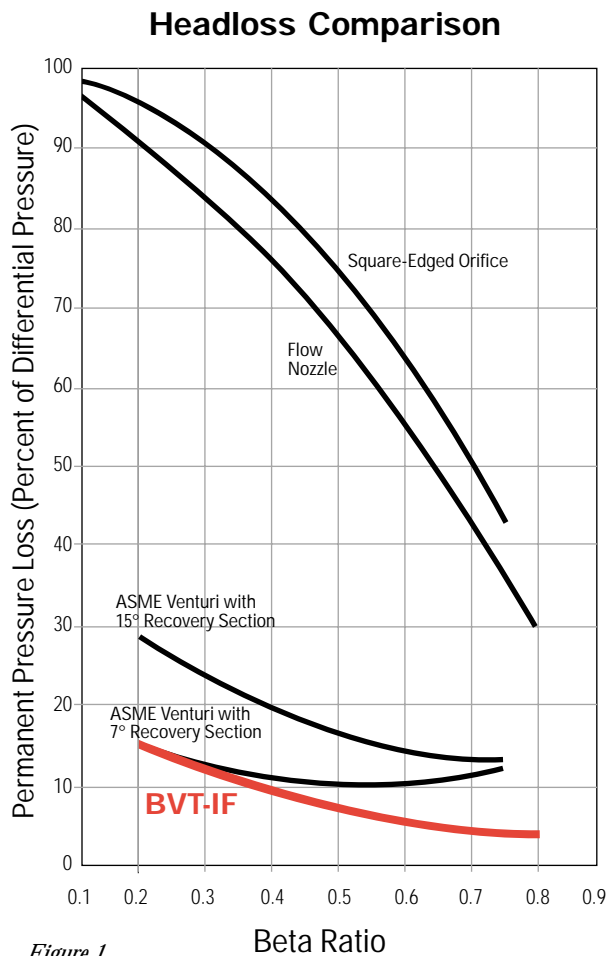

Figure 1

## Beta Ratio

Wyatt can furnish BVT-IF meters with a wide range diameter ratios (d/D). This provides users with accurate flow measurement over a broad range of flow rates for a given line size.

## Temperature Range

The fabricated series of the BVT-IF can operate over a fluid temperature range of -325 °F to +1200 °F (-200 °C to +650 °C).

## Pressure Range/Flange Connections

The BVT-IF is designed to operate within the pressure boundary of 4000 PSIG (27 500 kPaG) and can be manufactured to interface with any flange geometry.

## Piping Requirements

Designed for full-pipe flow, BVT flow meters can be mounted horizontally or vertically. For recommended upstream piping, refer to Wyatt Engineering Technical Manual for the BVT.

## Design Concepts

The hydraulic design produces discharge coefficients that are highly predictable and independent of line size. The BVT-IF design allows accurate calculation of expansibility factors that are necessary for compressible fluid flow measurement. The smooth transition section minimizes flow noise and erosion.

## Signal-to-Noise Ratio

Within the specified flow range and piping conditions, the BVT-IF will produce signal-to-noise ratios greater than 98%. This level of performance is essential for sensitive process control and reactive rate-of-flow control applications.

# BVT-IF Sizing Table



Pipe Inside Diameter		Throat Diameter		Beta Ratio	Overall Length		Outlet Diameter		ΔP = Differential Pressure of 100" wc (24.864 kPa)						
(inches)	(mm)	(inches)	(mm)		(inches)	(mm)	(inches)	(mm)	Water Flow at 60 F (16 C)				ΔH = Headloss		
									US GPM	US MGD	LPS	m <sup>3</sup> /d	R <sub>D</sub> (10 <sup>-3</sup> )	in. wc	kPa
3.000	76.2	1.500	38.1	0.5000	7.60	193.0	2.30	58.4	128.98	0.186	8.14	703.10	121	9.5	2.36
3.000	76.2	1.800	45.7	0.6000	7.70	195.6	2.60	66.0	189.97	0.274	11.99	1035.53	179	6.7	1.67
3.000	76.2	2.100	53.3	0.7000	7.70	195.6	2.80	71.1	267.94	0.386	16.90	1460.54	252	4.2	1.05
4.000	101.6	2.000	50.8	0.5000	10.10	256.5	3.00	76.2	229.31	0.330	14.47	1249.95	162	9.2	2.28
4.000	101.6	2.400	61.0	0.6000	10.20	259.1	3.40	86.4	337.73	0.486	21.31	1840.94	239	6.5	1.62
4.000	101.6	2.800	71.1	0.7000	10.30	261.6	3.80	96.5	476.34	0.686	30.05	2596.52	336	4.1	1.01
6.000	152.4	3.000	76.2	0.5000	15.20	386.1	4.60	116.8	515.94	0.743	32.55	2812.38	243	8.7	2.17
6.000	152.4	3.600	91.4	0.6000	15.30	388.6	5.20	132.1	759.88	1.094	47.94	4142.12	358	6.2	1.54
6.000	152.4	4.200	106.7	0.7000	15.40	391.2	5.70	144.8	1071.76	1.543	67.62	5842.17	505	3.9	0.96
8.000	203.2	4.000	101.6	0.5000	20.20	513.1	6.10	154.9	917.23	1.321	57.87	4999.79	324	8.4	2.10
8.000	203.2	4.800	121.9	0.6000	20.40	518.2	6.90	175.3	1350.90	1.945	85.23	7363.77	477	6.0	1.49
8.000	203.2	5.600	142.2	0.7000	20.60	523.2	7.60	193.0	1905.36	2.744	120.21	10386.08	673	3.7	0.93
10.000	254.0	5.000	127.0	0.5000	25.20	640.1	7.70	195.6	1433.17	2.064	90.42	7812.18	405	8.2	2.04
10.000	254.0	6.000	152.4	0.6000	25.50	647.7	8.70	221.0	2110.79	3.040	133.17	11505.89	596	5.8	1.45
10.000	254.0	7.000	177.8	0.7000	25.70	652.8	9.50	241.3	2977.12	4.287	187.83	16228.25	841	3.7	0.91
12.000	304.8	6.000	152.4	0.5000	30.30	769.6	9.20	233.7	2063.76	2.972	130.20	11249.54	486	8.0	2.00
12.000	304.8	7.200	182.9	0.6000	30.60	777.2	10.40	264.2	3039.53	4.377	191.76	16568.48	716	5.7	1.42
12.000	304.8	8.400	213.4	0.7000	30.80	782.3	11.40	289.6	4287.05	6.173	270.47	23368.68	1009	3.6	0.89
14.000	355.6	7.000	177.8	0.5000	35.30	896.6	10.80	274.3	2809.01	4.045	177.22	15311.87	567	7.9	1.96
14.000	355.6	8.400	213.4	0.6000	35.70	906.8	12.10	307.3	4137.14	5.957	261.01	22551.54	835	5.6	1.39
14.000	355.6	9.800	248.9	0.7000	36.00	914.4	13.30	337.8	5835.15	8.403	368.14	31807.37	1178	3.5	0.87
16.000	406.4	8.000	203.2	0.5000	40.30	1023.6	12.30	312.4	3668.90	5.283	231.47	19999.17	648	7.8	1.93
16.000	406.4	9.600	243.8	0.6000	40.80	1036.3	13.90	353.1	5403.62	7.781	340.92	29455.08	954	5.5	1.37
16.000	406.4	11.200	284.5	0.7000	41.10	1043.9	15.30	388.6	7621.42	10.975	480.84	41544.31	1346	3.5	0.86
18.000	457.2	9.000	228.6	0.5000	45.40	1153.2	13.80	350.5	4643.46	6.687	292.96	25311.46	729	7.7	1.90
18.000	457.2	10.800	274.3	0.6000	45.90	1165.9	15.60	396.2	6838.95	9.848	431.47	37279.08	1073	5.4	1.35
18.000	457.2	12.600	320.0	0.7000	46.20	1173.5	17.20	436.9	9645.86	13.890	608.56	52579.52	1514	3.4	0.85
20.000	508.0	10.000	254.0	0.5000	50.40	1280.2	15.40	391.2	5732.66	8.255	361.67	31248.71	810	7.6	1.88
20.000	508.0	12.000	304.8	0.6000	51.00	1295.4	17.40	442.0	8443.15	12.158	532.68	46023.56	1193	5.4	1.33
20.000	508.0	14.000	355.6	0.7000	51.30	1303.0	19.10	485.1	11908.47	17.148	751.31	64912.99	1682	3.4	0.84
24.000	609.6	12.000	304.8	0.5000	60.50	1536.7	18.50	469.9	8255.04	11.887	520.81	44998.14	972	7.4	1.84
24.000	609.6	14.400	365.8	0.6000	61.20	1554.5	20.90	530.9	12158.14	17.508	767.06	66273.92	1431	5.2	1.30
24.000	609.6	16.800	426.7	0.7000	61.60	1564.6	22.90	581.7	17148.20	24.693	1081.88	93474.71	2019	3.3	0.82
30.000	762.0	15.000	381.0	0.5000	75.60	1920.2	23.10	586.7	12898.49	18.574	813.77	70309.60	1215	7.2	1.79
30.000	762.0	18.000	457.2	0.6000	76.50	1943.1	26.10	662.9	18997.09	27.356	1198.53	103553.00	1789	5.1	1.27
30.000	762.0	21.000	533.4	0.7000	77.00	1955.8	28.70	729.0	26794.06	38.583	1690.44	146054.23	2523	3.2	0.80
36.000	914.4	18.000	457.2	0.5000	90.70	2303.8	27.70	703.6	18573.83	26.746	1171.83	101245.82	1458	7.0	1.75
36.000	914.4	21.600	548.6	0.6000	91.80	2331.7	31.30	795.0	27355.81	39.392	1725.88	149116.32	2147	5.0	1.24
36.000	914.4	25.200	640.1	0.7000	92.40	2347.0	34.40	873.8	38583.45	55.560	2434.24	210318.09	3028	3.1	0.78
42.000	1066.8	21.000	533.4	0.5000	105.80	2687.3	32.40	823.0	25281.05	36.405	1594.99	137806.81	1701	6.9	1.72
42.000	1066.8	25.200	640.1	0.6000	107.10	2720.3	36.50	927.1	37234.29	53.617	2349.12	202963.88	2505	4.9	1.22
42.000	1066.8	29.400	746.8	0.7000	107.80	2738.1	40.10	1019	52516.36	75.624	3313.27	286266.29	3533	3.1	0.76
48.000	1219.2	24.000	609.6	0.5000	120.90	3070.9	37.00	939.8	33020.14	47.549	2083.25	179992.57	1944	6.8	1.69
48.000	1219.2	28.800	731.5	0.6000	122.40	3109.0	41.80	1062	48632.55	70.031	3068.24	265095.68	2863	4.8	1.20
48.000	1219.2	33.600	853.4	0.7000	123.10	3126.7	45.90	1165.9	68592.79	98.774	4327.53	373898.83	4037	3.0	0.75

This sizing table can be used as a guide to aid the user in choosing the proper insert BVT for a given application and reflects the most commonly-used sizes. Other sizes and special geometries are available, often at no additional cost. Depending on the details of your application, a more appropriate selection, or a more accurate estimation of the performance of a given selection, may be available. Wyatt Engineering encourages users to contact their local Wyatt-Badger representatives, or call us directly, for definitive sizing information.

### Incompressible Flow Relationships

$$\Delta P_N = 100 (Q_N / Q)^2$$

$$\Delta H_N = \Delta H (Q_N / Q)^{1.88}$$

$$Q_N = Q (\Delta P / 100)^{0.5}$$

### Examples:

For a 20.00" x 14.000" BVT-IF, find  
 ΔP at 20 000 US GPM  
 ΔH at 20 000 US GPM  
 Q<sub>N</sub> at 750" wc

### Solutions:

Found using the "Incompressible Flow Relationships"  
 $\Delta P_N = 100 (20\ 000 / 11\ 908.47)^2 = 282.06"$  wc  
 $\Delta H_N = 3.4 (20\ 000 / 11\ 908.47)^{1.88} = 9.0"$  wc  
 $Q_N = 11\ 908.47 (750 / 100)^{0.5} = 32\ 612.69$  US GPM

# Available Options



## Materials of Construction

The nature of the BVT-IF fabricated design allows the flow element to be constructed from practically any material. Examples of some of the alloys employed:

- Carbon Steel
- 304 Stainless Steel
- 316 Stainless Steel
- Inconel
- Hastelloy B & C
- Monel
- Titanium
- Chrome Molybdenum
- Nickel
- Tantalum
- Zirconium

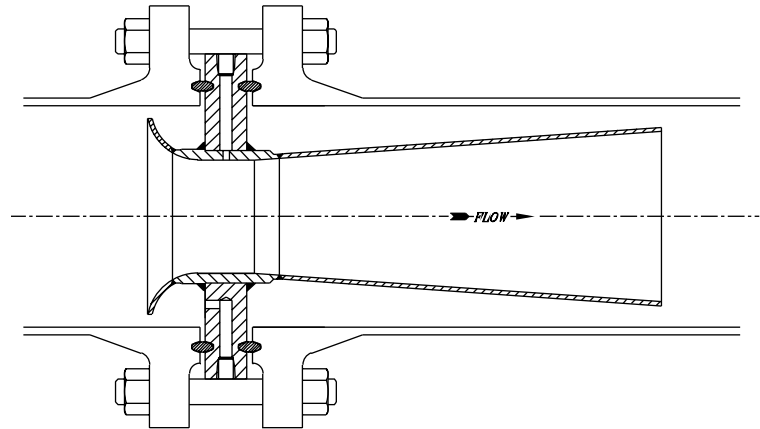

BVT-IF

*Consult your local representative or Wyatt Engineering for information on other materials of construction.*

---

---



**WYATT**  
engineering  
*Intelligent Flow Measurement™*